

NIDECKER — HYBRID BINDINGS

FOR KAON-CX, KAONPLUS, KAON-W PLUS & KAON-W



Thank you for purchasing Nidecker bindings. We recommend that your bindings be mounted and maintained by a trained, professional mechanic.

Tools needed:
Screwdriver



PH#3

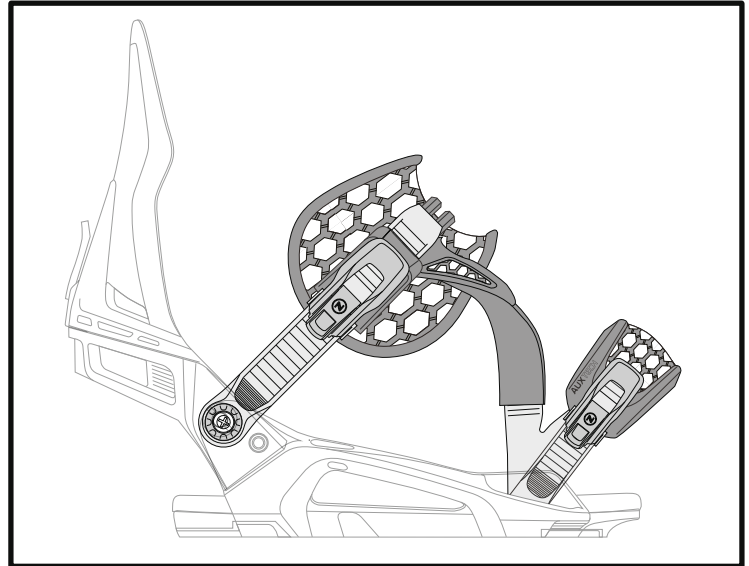

All Nidecker bindings can be fully personalized for a superior fit to your boot and riding style. Please go to www.NIDECKER.com for videos, details and tricks & tips for each of our models.

BUCKLE REPLACEMENT

On topside, attach buckle with supplied screw into spiked T-nut, using Philips #2 screwdriver.

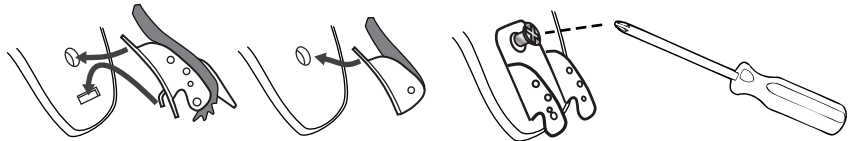

CHANGE YOUR LADDERSTRAP

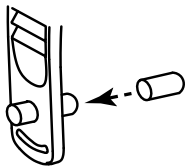

Use ladderstraps with this bottom shape and attachment pins. Insert ladderstraps from top into the slots, add stopper pins into ladders from bottom.

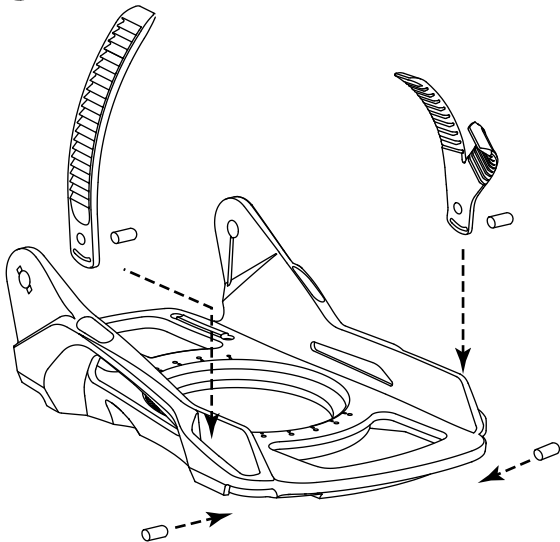

CHANGE YOUR HIBACK

Remove the two outer screws on the top straps.

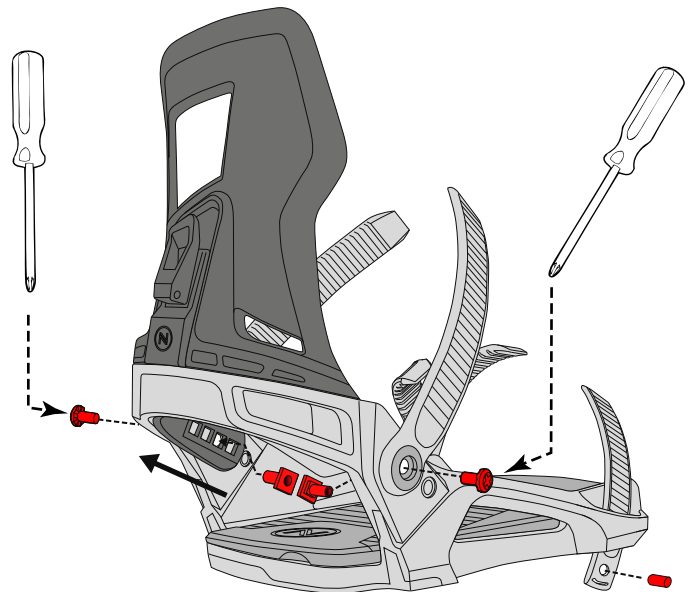

IMPORTANT NOTE: Be sure that all parts are assembled correctly and secure, failure to do so may cause serious injuries. Nidecker recommends that any and all service and repairs to your bindings be done by a trained, professional mechanic. For our full liability policy, how-to tricks and tips and more, please visit WWW.NIDECKER.COM



NIDECKER — CLASSICS BINDINGS

FOR KAON-X, KAON-W, MUON-X, MUON-W & PRIME



Thank you for purchasing Nidecker bindings. We recommend that your bindings be mounted and maintained by a trained, professional mechanic.

Tools needed:
Screwdriver



PH#3

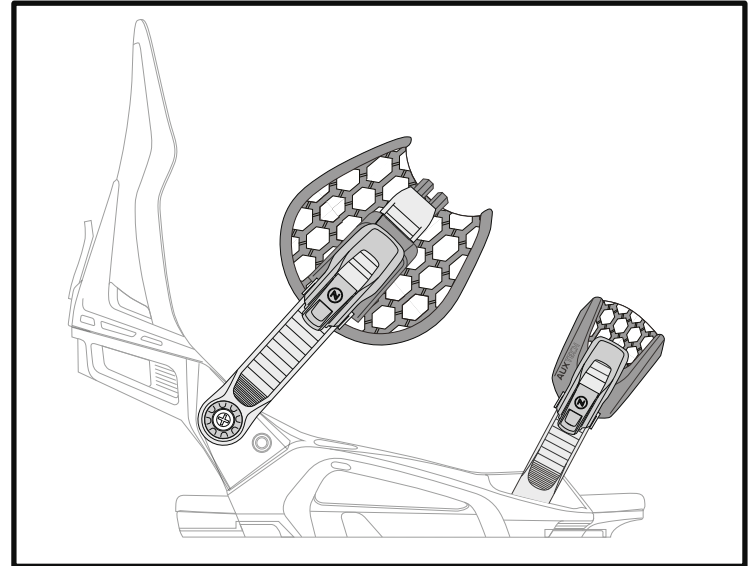

All Nidecker bindings can be fully personalized for a superior fit to your boot and riding style. Please go to www.NIDECKER.com for videos, details and tricks & tips for each of our models.

BUCKLE REPLACEMENT

On topside, attach buckle with supplied screw into spiked T-nut, using Philips #2 screwdriver.

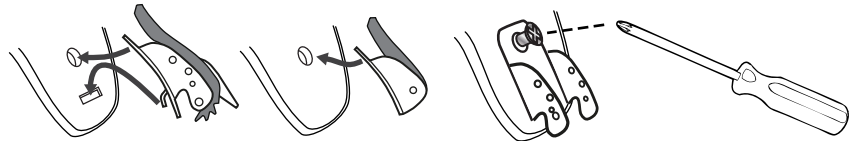

CHANGE YOUR LADDERSTRAP

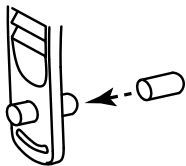

Use ladderstraps with this bottom shape and attachment pins. Insert ladderstraps from top into the slots, add stopper pins into ladders from bottom.

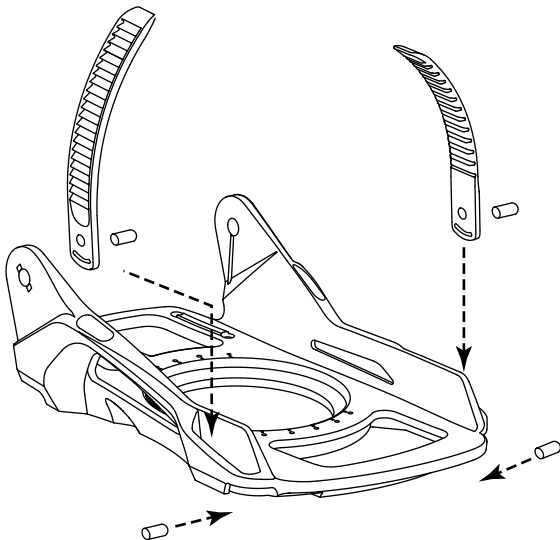

CHANGE YOUR HIBACK

Remove the two outer screws on the top straps.

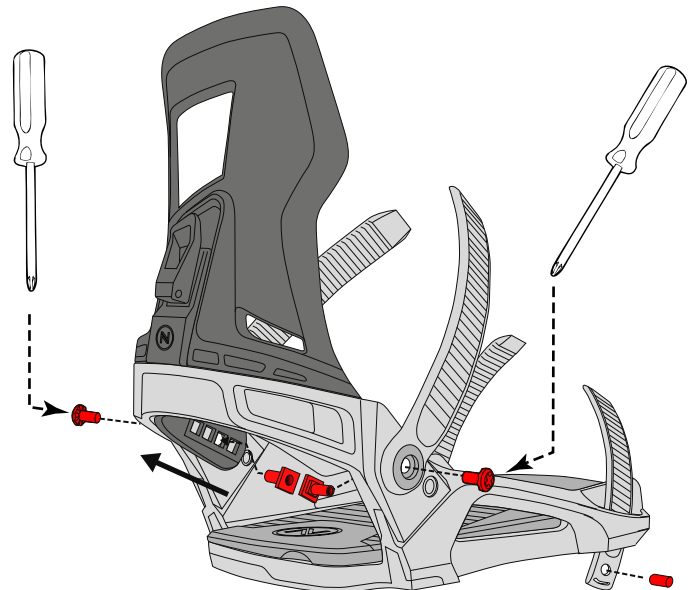

IMPORTANT NOTE: Be sure that all parts are assembled correctly and secure, failure to do so may cause serious injuries. Nidecker recommends that any and all service and repairs to your bindings be done by a trained, professional mechanic. For our full liability policy, how-to tricks and tips and more, please visit WWW.NIDECKER.COM

